

EX-SDI 2.0

ADVANCED IR LED DOME CAMERA

1/2.8 inch SONY CMOS (IMX-291)

0 Lux at IR On (IR LED 02 pcs) / DNR (Digital Noise Reduction)

WDR (Wide Dynamic Range) / Day & Night (ICR Option) / Easy Installation

Fixed Lens 4.3mm, 6mm



DOMES DIMENSIONS (mm)

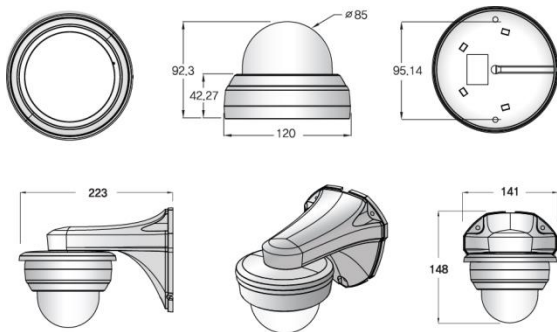

Specification	ISQ-77H2
Resolution	1080P, 720P,
Sensor	1/2.8 inch SONY CMOS (IMX-291)
Total Pixels	1945(H) x 1109(V) = 2.16M
Effective Pixels	1945(H) X 1097(V) = 2.13M
Scanning System	PROGRESSIVE
S/N (Y signal)	More than 52 dB (AGC Off)
Video Output	SMPT292M (EX-SDI, HD-SDI) / (TVI, CVI, CVBS: 1.0Vp-p (75ohm) : Option)
Min.Illumination	0 Lux at IR On
White Balance	AUTO / AUTO EXT / PRESET / MANUAL
Electronic shutter speed	AUTO / MANUAL (1/30sec ~ 1/30,000sec) / FLICKER
SENS_UP	OFF / X2 ~ x32
DNR / ACE	OFF / LOW / MIDDLE / HIGH
BACKLIGHT	OFF / WDR / BLC / HLC
Day & Night	AUTO (Day <--> Night TIME Change) , COLOR , B/W, EXTERN
PRIVACY / FLIP / MOTION / DEFOG	OFF / ON
Language	ENG, CHN, CHN(S), JPN, KOR
Sharpness / Smart IR / Brightness	ADJUSTABLE (Sharpness : 0 ~ 10 STEP / Smart IR, Brightness : 0 ~ 20 STEP)
COMM.	RS-485(PELCO-D)
Temperature/Humidity	Operating (-10°C~+50°C / 30%~80% RH) / Storage (-20°C~+60°C / 20%~90% RH)
Power	DC12V [AC24V / DC12V DualPower (option)]
signal Transmission	The distant difference is occurred according to cable option and other circumstances. (based on 5C-HFBT : HD-SDI (200M) / EX-SDI (500M))